

TORQUEMASTER

BRUSH SERVO MOTORS

MS15 SERIES

Torque Systems specializes in the design of high performance brush servo motors that provide efficiency, flexibility of application, and a long and trouble-free service life. Our TORQUEMASTER® MS15 series is no exception when integrated with high performance brush amplifiers, TORQUE-MASTER MS15 Series brush servo motors provide effective and highly efficient motion control solutions for a wide range of applications including factory automation, packaging, robotics, machine tools, medical instrumentation and more.



Performance Benefits:

- Delivers smooth and superior low speed performance, and maximum power ratings with low thermal resistance for high speed performance.
- Maximum torque in a smaller 1.5" O.D.package
- Rugged industrial construction
- Continuous torque ratings up to 10 oz.-in with a *Max speed at 10000 RPM.*
- Power up to 50 Watts (Peak)
- Peak torque ratings up to 77.8 oz.-in.
- High torque-to-inertia ratio delivers maximum torque per frame size
- Custom options available

Design Features:

- Dual Stage Dynamic Balancing
- Diamond Finished Commutators
- ABEC 3 Double Shielded Ball Bearings
- Low Torque Ripple
- Stainless Steel Shafts
- 100% Inspection and Testing
- Tapered-Field Magnet Technology
- Replaceable Copper Graphite Brushes
- Fully Neutralized, Bidirectional Operation

MS15 PERFORMANCE CHART

Power Option			09				17				25			
Voltage option			A(12V)	B(24V)	C(36V)	D(48V)	A(12V)	B(24V)	C(36V)	D(48V)	A(12V)	B(24V)	C(36V)	D(48V)
Parameters	Symbol	Unit												
Rated Voltage Range	Vrange	V	0-15	0-30	0-45	0-60	0-15	0-30	0-45	0-60	0-15	0-30	0-45	0-60
Rated Output Power	Pout	Watts	30	30	30	30	40	40	40	40	50	50	50	50
No Load Speed	Snl	RPM	8000	8000	8000	8000	8000	8000	8000	8000	8000	8000	8000	8000
Rated Speed	Sr	RPM	6700	6700	6700	6700	6700	6700	6700	6700	6700	6700	6700	6700
Max Speed	Smax	RPM	10000	10000	10000	10000	10000	10000	10000	10000	10000	10000	10000	10000
Rated Torque	Tr	oz in	6	6	6	6	8	8	8	8	10	10	10	10
		N cm	4.24	4.24	4.24	4.24	5.65	5.65	5.65	5.65	7.06	7.06	7.06	7.06
Peak Torque	Tp	oz in	43	43	43	43	58.8	58.8	58.8	58.8	77.8	77.8	77.8	77.8
		N cm	30.36	30.36	30.36	30.36	41.51	41.51	41.51	41.51	54.93	54.93	54.93	54.93
Thermal Resistance*	Rm	C/w	8.7	8.7	8.7	8.7	6.2	6.2	6.2	6.2	4.1	4.1	4.1	4.1
Thermal Time Constant*	rtm	min	20	20	20	20	20	20	20	20	20	20	20	20
Mech. Time Constant	tm	ms	19	19	19	19	22	22	22	22	24	24	24	24
Amature Inertia	Ja	oz -in s ²	0.001	0.001	0.001	0.001	0.001	0.001	0.001	0.001	0.001	0.001	0.001	0.001
		kg m ²	0.000	0.000	0.000	0.000	0.000	0.000	0.000	0.000	0.000	0.000	0.000	0.000
Max. Acceleration	εmax	kRad/s ²	65	65	65	65	55	55	55	55	45	45	45	45
Back_EMF Constant	Ke	V/KRPM	1.4	2.7	4.4	5.5	1.7	2.8	4.5	5.7	1.5	3	4.5	6
		V/rad/s	0.013	0.026	0.042	0.053	0.016	0.027	0.043	0.054	0.014	0.029	0.043	0.057
Torque Constant	Kt	oz-in/A	1.89	3.65	5.99	7.42	2.3	3.75	6.08	7.7	2.04	4.08	6.08	8.17
		N m/A	0.013	0.026	0.042	0.052	0.016	0.026	0.043	0.054	0.014	0.029	0.043	0.058
No Load Current	Inl	A	0.53	0.27	0.12	0.13	0.65	0.26	0.16	0.13	0.74	0.36	0.23	0.17
Rated Current	Ir	A	3.25	1.68	1	0.83	3.66	2.22	1.38	1.09	4.5	2.45	1.63	1.22
Peak Current	Ip	A	22.7	11.8	8.2	5.8	31	15.6	9.7	7.6	48.7	24.35	16.22	12.17
Terminal Resistance	R	Ω	0.72	2.7	6.4	10.26	0.87	1.8	3.8	5.94	0.31	1.23	2.55	4.73

Flange Dimensions	D	in	1.5				1.5				1.5			
Axial Length	AL	In	2.5	2.5	2.5	2.5	3.25	3.25	3.25	3.25	4.122	4.122	4.122	4.122
Weight	Wm	oz	8.4	8.4	8.4	8.4	12	12	12	12	16	16	16	16
Operating Temp,			-40 - 115				-40 - 115				-40 - 115			
Ingress Protection Rating			IP65				IP65				IP65			

* Custom voltages available
 * Values apply at rated voltage, torque & speeds
 ** Based on 10" x 10" x 1/4" Aluminum Plate Heatsink

MS1509-A

12 Vdc
 Motor Performance Chart

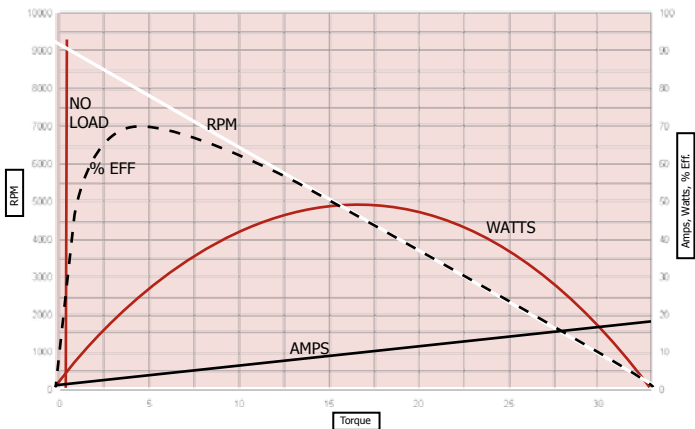

MS1525-A

12 Vdc
 Motor Performance Chart

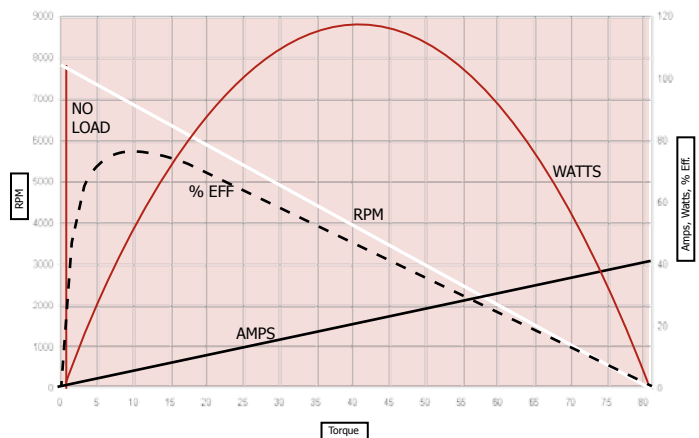

MECHANICAL SPECIFICATIONS*

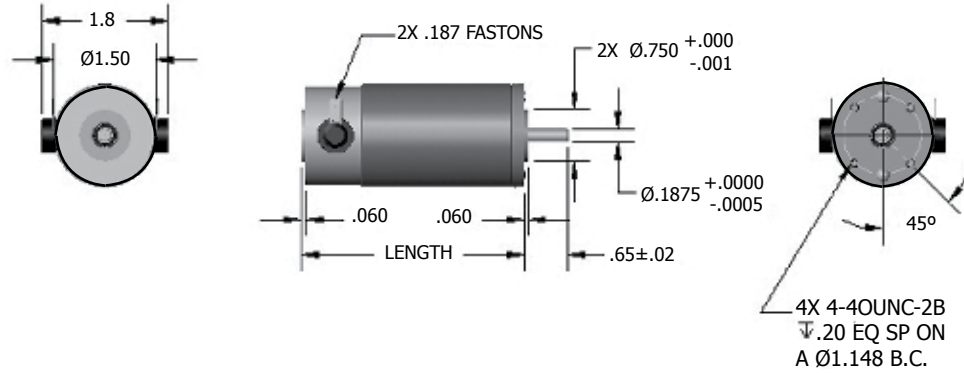

OPTIONS	Length	
	Inches	MM
MS1509	2.500	63.50
MS1517	3.250	82.55
MS1525	4.122	104.70

DIMENSION CHART*

MOTOR	LENGTH		SHAFT DIA.		SHAFT LENGTH		PILOT		PILOT DEPTH	
	Motor Only Inches (Metric)	Motor Tach Inches (Metric)	STD	NEMA-17	STD	NEMA	STD	NEMA	STD	NEMA
MS1509	2.50 (63.50)	3.00 (76.2)	.1875/.1870	.1969/.1964	.65	0.812+/-0.031	.75/.748	0.08661/0.08461	0.06	0.06+/-0.03
MS1517	3.25 (82.55)	3.75 (95.2)	.1875/.1870	.1969/.1964	.65	0.812+/-0.031	.75/.748	0.08661/0.08461	0.06	0.06+/-0.03
MS1525	4.10 (104.70)	4.55 (115.57)	.1875/.1870	.1969/.1964	.65	0.812+/-0.031	.75/.748	0.08661/0.08461	0.06	0.06+/-0.03

May include a "Flat" for NEMA: 0.185" across

*All specifications are for reference only. Please consult the factory for certified dimension drawings. Standard Direction of Rotation: CCW rotation viewed from shaft end with red motor terminal positive with respect to black motor terminal.

REAR OPTION-FAIL SAFE BRAKE DETAILS BELOW

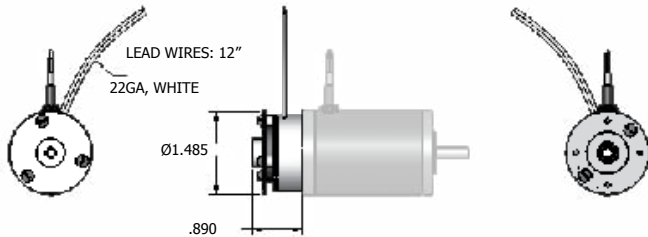

- Spring Applied Friction Brake.
- Failsafe brake is designed to hold or decelerate inertial loads when the voltage is turned off

TORQUE	1 LB-IN
VOLTAGE	24 VDC
CURRENT	.170 AMPS
INERTIA	.0004 LB-IN ²

FRONT OPTION- GI GEARHEAD DETAILS BELOW

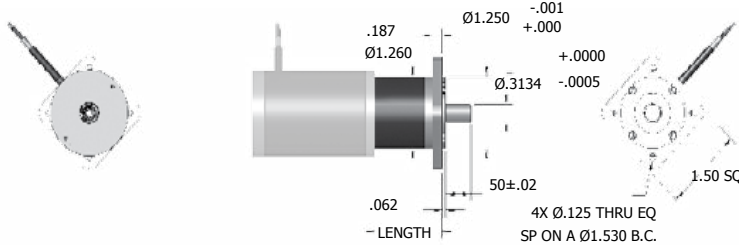

	005	016	025	036	064	125	256		
Ratio	5.18:1	15.88:1	25.01:1	34.97:1	68.06:1	123.97:1	252.24:1	493.18:1	1011.84:1
Length Inches	0.926	1.296	1.296	1.296	1.662	1.662	2.032	2.032	2.032
Peak Efficiency	80%	75%	75%	75%	70%	70%	65%	65%	65%
Max Backlash °Deg	2	1.55	1.55	1.55	1.60	1.60	1.65	1.65	1.65

Modular designed gearhead allows virtually unlimited motor flange options. Customize the output flange and shaft to fit your current application or use our standard flange for efficiency. Other options include: Plastic gears for quiet operation, Special seals for advance IP classifications, Stainless output shaft.

ORDERING INFORMATION (FOR STANDARD OPTIONS)

VOLTAGE EQUATION FOR MOTORS

Volts = $\frac{K_T \times \text{RPM}}{1,350} + \frac{T \times R_A}{K_T} + V_B$

Where:
 K_T = torque constant, oz.-in. per amp
 T = load torque plus motor friction torque-oz.-in.
 R_A = armature resistance + brush resistance
 V_B = brush voltage drop = 2 volts
Note: For armature resistance at maximum temperature rating, multiply catalog value of R by 1.5

MOTOR TORQUE RATING VS. SPEED

$T_R = .94K_T \left[\frac{130 - \text{RPM} \times T_F - \text{RPM}^2 \times F_i}{R_{TH} \times 1,350 - 1,350,000} \right]^{1/2} - T_F - \left[\frac{\text{RPM} \times F_i}{1000} \right]$

Where:
 T_R = rated torque (25°C ambient)-oz.-in.
 K_T = torque sensitivity-oz.-in./amp
 R_A = armature resistance
RPM = revolutions per minute
 T_F = static friction torque-oz.-in.
 F_i = viscous friction-oz.-in.
 R_{TH} = thermal resistance

To Find: Higher Torque Rating for Intermittent Duty

Let A = $\frac{\text{total cycle time in seconds}}{\text{thermal time constant of motors in seconds}}$

Let B = $\frac{\text{"on" time in seconds per cycle}}{\text{thermal time constant of motor in seconds}}$

then with T_R = Rated torque for 100% duty
and T_{MAX} = Rated torque for intermittent duty

$$T_{MAX} = T_R \times \left[\frac{1 - e^{-A}}{1 - e^{-B}} \right]^{1/2}$$

MS15 XX X XX X XX X X X - X X

FRAME SIZE

09
17
25

TACH OPTION

0 = None
T = Tach
S = Special

ENCODER OPTION

00 = None
M0 = Encoder Prep
Q_ = Quantum Enc.
QC = 500 PPR
QD = 1000 PPR
QE = 1024 PPR
QF = 1500 PPR
QG = 2000 PPR
QH = 2048 PPR
QJ = 2500 PPR
QK = 5000 PPR
SS = Special

BRAKE OPTION

0 = None
B = Fail Safe Brake
S = Special

TACH WINDING

W = 1V
A = 2V
E = 3V

MOTOR WINDING

A = 12V
B = 24V
C = 36V
D = 48V
see page 2 for KE (V/krpm)

MOUNTING OPTION

A = Standard Round
(1.5" diam; .748/.750" x .06" pilot;
4x #4-40 threads on 1.148" B.C.)
B = NEMA std
S = Special

SHAFT OPTION

A = .1875" x .65", round
B = NEMA 17 std
S = Special

TERMINAL OPTION

T = Std Tab Terminals
S = Special

GEARBOX OPTION

00 = None
GI = GearBox (specify ratio)
SS = Special

Customize The MS15 Series To Your Exact Requirements

To satisfy various applications with cost-effective solutions, MS15 Series motors are readily available with a wide range of standard capabilities. Final designs are often the result of cooperative efforts between the customer's engineering department and Torque Systems. For assistance, call your local distributor or Torque Systems direct. We look forward to meeting your custom requirements.

Ask About Other Motion Control Solutions & capabilities From Torque Systems

- Brushless TorqueMaster® Servo Motors
- Gearboxes/Brakes
- Expert application engineering
- Complete repair & refurbishing services



Torque Systems
6 Enterprise Road
Billerica, MA 01821
Tel: 978.667.5100 or 1.800.669.5112
Fax: 978.600.0280
sales: customer@slmti.com
www.torquesystems.com

